

CARGOFLO

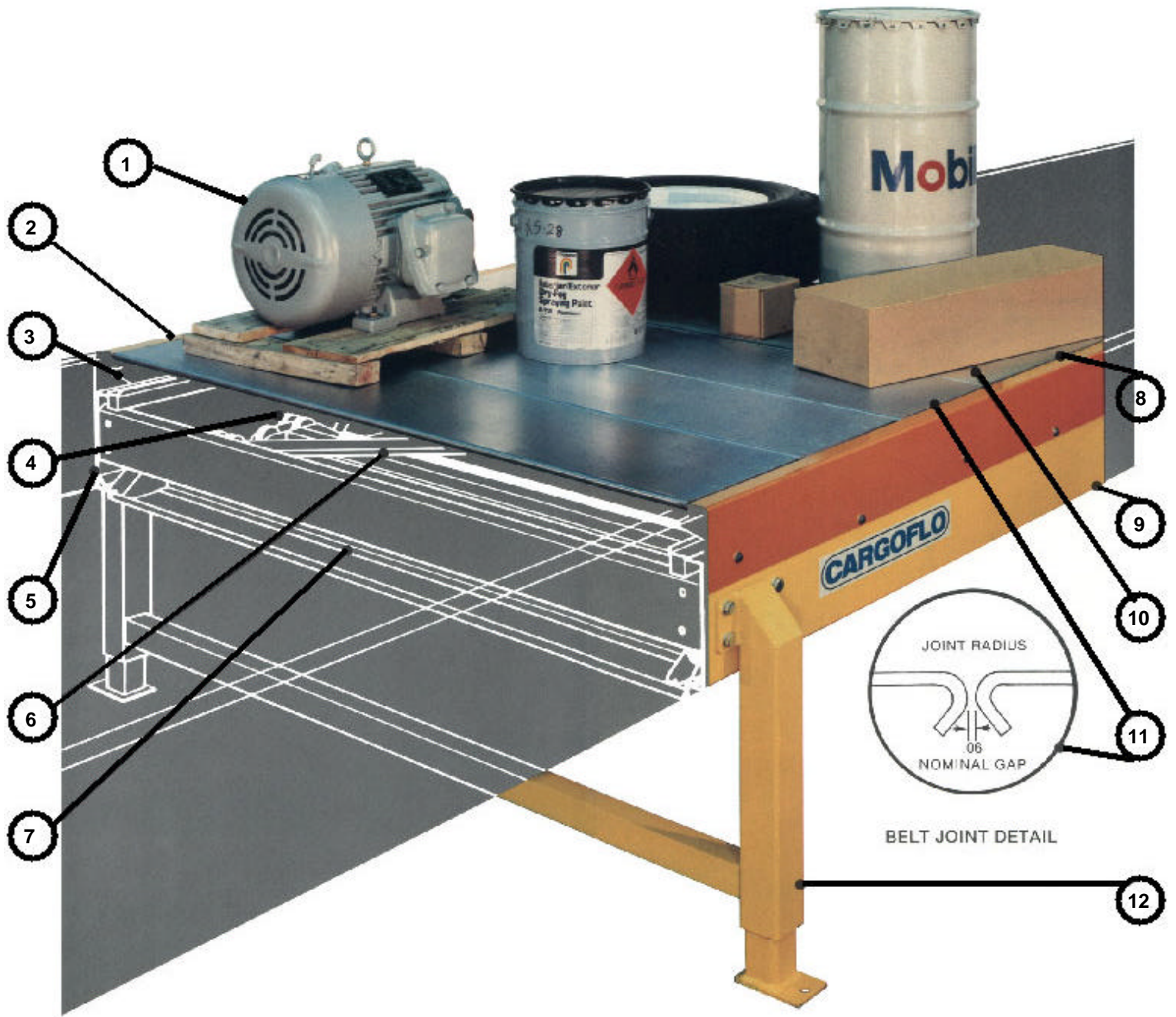

*Reliable, heavy duty conveying
for nonstop,
around-the-clock operations*



- | | |
|---|---|
| <ul style="list-style-type: none"> 1. Heavy Load Capacity 2. Self Tracking Belt
Zinc Coated Steel 3. Heavy Duty Manganese Steel
Tracks 4. Ball Bearing Load Rollers 5. Easy To Assemble 10' Long
Welded Sections 6. Internal Bracing For Permanent
Square Frame | <ul style="list-style-type: none"> 7. Heavy Duty Reinforcement Of Belt
Sections 8. Minimum Gap Between Belt And
Frame For Safety 9. Clean, Safe Full Closure 10. Smooth Non-Tear Belt
Easy On/Off Loading 11. Smooth Rounded Edges
Minimum Gap 12. Tubular Legs, Adjustable Feet On
10' Centers |
|---|---|



Dimensions And Specifications

Capacity:

1,000 lb per foot of length
64,000 lb max per conveyor (total load)

Speed:

Fixed or variable in range of 0-100 FPM

Horsepower:

Max: 6 HP at 100 FPM
1.6 HP at 10 FPM

Controls:

Start, stop, forward, reverse stations mounted but not wired on each end section.

Shipment:

Head, tail sections, drive, lubricator each on pallets.
Intermediate bodies in strapped bundles on skids.

